



Eclipse Guided Wave Radar Level Application Questionnaire

(Please fill out front and back.)

REFERENCE INFORMATION

Customer/Company: _____
 City, State, Country: _____ SIC: _____ Date: _____
 Contact/Title: _____
 Phone: _____ Fax: _____ E-mail: _____
 RFQ Number: _____ P. O. Number: _____
 Tag Number(s): _____
 Submitted by: Rep Agency and Salesperson _____ Rep Code: _____

FOR OFFICE USE:

INSTRUMENT

Model Number: Electronics — — Quantity: _____
 Sensor/Probe — —

When Probe Models 7XB, 7XF, 7XJ, 7X1, 7X2, 7X5, and 7X7 are ordered, Figures 1 & 4 on back must be completed. Torque tube replacements must confirm flange dimensions on back (Figure 2).

PROCESS DATA

Process Name/Description: _____
 Process Media: _____
 Steam present: Yes No If yes, use Aegis PF128 O-ring or 7XS steam probe
 Liquid: % Concentration _____ Slurry % Solids _____
 Process Temperature: AMB _____ min. _____ max. ° F ° C Other
 Process Pressure: ATMOS _____ min. _____ max. PSIG Bar KPA Other
 Temperature at Instrument: AMB _____ min. _____ max. ° F ° C Other
 Media Constants: Dielectric Constant: _____ Conductivity: _____ (µ siemen/cm) Varies? No Yes, from _____ to _____
 Interface Dielectric of lower material: _____ Emulsion Layer: No Yes (If yes, thickness: _____)
 Viscosity: _____ Centipoise @ Temperature _____ ° F ° C
 Will media coat probe? No Yes: Film or Bridging Solids % Moisture: _____ Bulk Density: _____
 Environment: Normal Corrosive Salt Flood Maximum Viscosity: _____ centipoise
 Agency: FM CSA Area Classification: General Purpose (Nema 4X) Hazardous: Cl _____ Div _____ Group _____
 ATEX EEx Hazardous Area Design: Explosion-proof Intrinsically Safe Nonincendive SIL 2 Other
 Remote Instrument (if applicable): _____
 Required Materials of Construction: _____
 Vessel Type: Vertical Cylindrical Horizontal Cylindrical Sphere Sump/Pit O.C.F. Other _____
 Vessel Size: Height _____ Width _____ Diameter _____ Unit of Measure _____
 Tank Material of Construction: Metal Lined: Yes No Coated: Yes No Plastic Concrete
 Type of Filling: Top Bottom Side (At what level? _____)
 Liquid Surface: Calm Moderate Turbulence Vortex Flowing Foam Present: Yes No
 Does liquid boil and/or flash: Yes No
 Agitation: No Yes During Filling During Emptying Between Fill and Empty # and Size of Blades _____ RPM _____
 Other Objects in Vessel: No Yes _____ (Include sketch on back.)
 Minimum distance from probe rod to any metallic object (i.e., nozzle, tank wall, ladder, etc.): _____
 Foundation Fieldbus Host System: _____

PERFORMANCE

Measurement requirement (with respect to the bottom of the vessel):
 What is the maximum level height of the material?: _____ Unit of Measure: _____
 What is the minimum level height of the material?: _____ Unit of Measure: _____
 The typical operating level is _____ Unit of Measure: _____
 Accuracy Required:
 During filling: _____ % During emptying: _____ %
 When level is stationary: _____ %
 When level is stationary and agitated: _____ %

High Level Shutdown/Overfill Protection

Special consideration is necessary in any application for High Level Shutdown/Overfill protection. To ensure proper measurement, use the 7XR or 7XD probe, or install all other probes so the maximum overfill level is a minimum of 6" (150mm) below the process connection. This may include utilizing a nozzle or spool piece to raise the probe. Consult factory for further information.

FIGURE 2 - NON-ANSI FLANGES

When attempting to mate to an existing torque tube transmitter cage flange, confirm flange dimensions below.

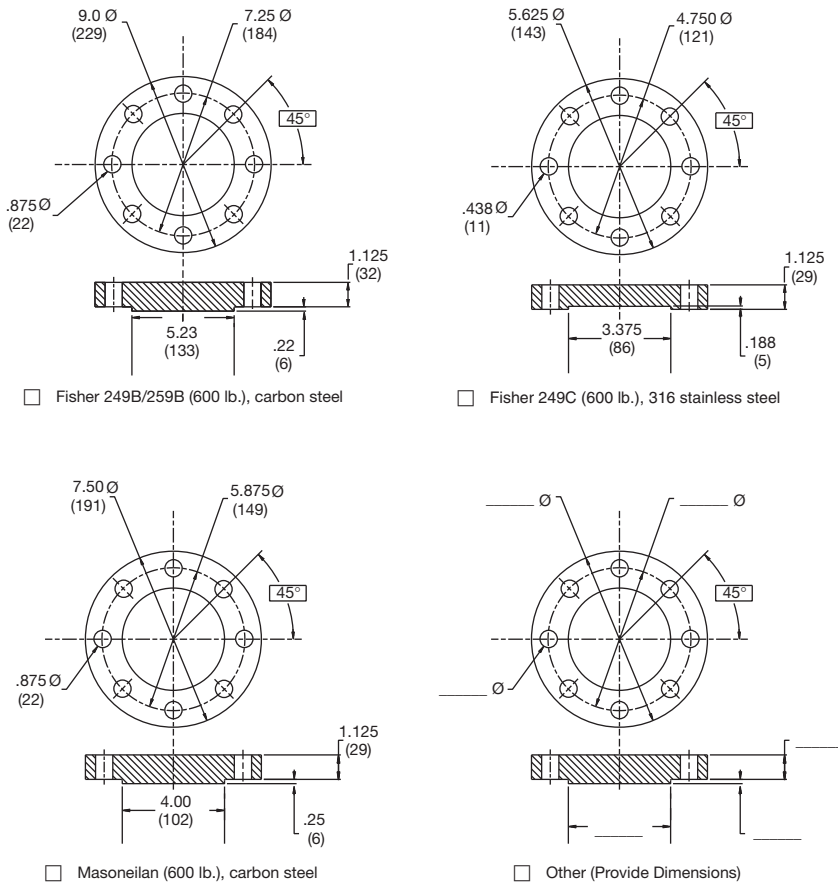
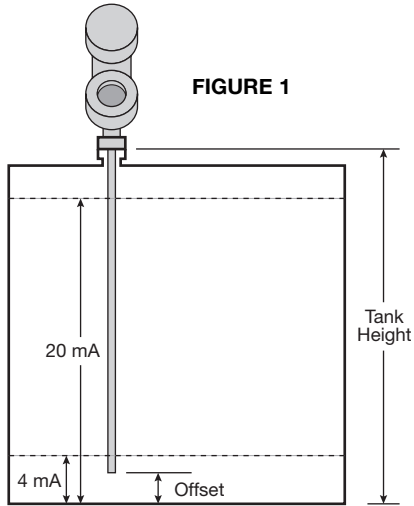

FIGURE 3 - RECOMMENDED SINGLE ROD PROBE CLEARANCE TABLE

Distance to Probe	Acceptable Objects
< 6"	Continuous, smooth, parallel conductive surface, for example a metal tank wall; important that probe does not touch wall
> 6"	<1" (25mm) diameter pipe and beams, ladder rungs
> 12"	<3" (75mm) diameter pipe and beams, concrete walls
> 18"	All remaining objects

FIGURE 4 - NOZZLES – Single Rod Probes

