

Top Mounting T20 and T21

Installation and Operating Manual



Liquid

Level

Switches

Read this Manual Before Installing

This manual provides information on the Top Mounting Liquid Level Switch. It is important that all instructions are read carefully and followed in sequence. Detailed instructions are included in the Installation section of this manual.

Conventions Used in this Manual

Certain conventions are used in this manual to convey specific types of information. General technical material, support data, and safety information are presented in narrative form. The following styles are used for notes, cautions, and warnings.

NOTES

Notes contain information that augments or clarifies an operating step. Notes do not normally contain actions. They follow the procedural steps to which they refer.

Cautions

Cautions alert the technician to special conditions that could injure personnel, damage equipment, or reduce a component's mechanical integrity. Cautions are also used to alert the technician to unsafe practices or the need for special protective equipment or specific materials. In this manual, a caution box indicates a potentially hazardous situation which, if not avoided, may result in minor or moderate injury.

WARNINGS

Warnings identify potentially dangerous situations or serious hazards. In this manual, a warning indicates an imminently hazardous situation which, if not avoided, could result in serious injury or death.

Safety Messages

Follow all standard industry procedures for servicing electrical equipment when working with or around high voltage. Always shut off the power supply before touching any components.

WARNING! Explosion hazard. Do not connect or disconnect equipment unless power has been switched off or the area is known to be non-hazardous.

Low Voltage Directive

For use in Category II installations. If equipment is used in a manner not specified by manufacturer, protection provided by equipment may be impaired.

Notice of Trademark, Copyright, and Limitations

Magnetrol® & MAGNETROL logotype are registered trademarks of MAGNETROL International.

Copyright © 2019 MAGNETROL International, Incorporated. All rights reserved.

Performance specifications are effective with date of issue and are subject to change without notice. MAGNETROL reserves the right to make changes to the product described in this manual at any time without notice. MAGNETROL makes no warranty with respect to the accuracy of the information in this manual.

Warranty

All MAGNETROL mechanical level and flow controls are warranted free of defects in materials or workmanship for five full years from the date of original factory shipment.

If returned within the warranty period; and, upon factory inspection of the control, the cause of the claim is determined to be covered under the warranty; then, MAGNETROL will repair or replace the control at no cost to the purchaser (or owner) other than transportation.

MAGNETROL shall not be liable for misapplication, labor claims, direct or consequential damage or expense arising from the installation or use of equipment. There are no other warranties expressed or implied, except special written warranties covering some MAGNETROL products.

Quality Assurance

The quality assurance system in place at MAGNETROL guarantees the highest level of quality throughout the company. MAGNETROL is committed to providing full customer satisfaction both in quality products and quality service.

The MAGNETROL quality assurance system is registered to ISO 9001 affirming its commitment to known international quality standards providing the strongest assurance of product/service quality available.

Top Mounting Liquid Level Switches

Table of Contents

1.0 Introduction		5.0 Reference Information	
1.1 Principle of Operation.....	4	5.1 Troubleshooting.....	12
2.0 Installation		5.1.1 Check switch mechanism.....	12
2.1 Unpacking.....	4	5.1.2 Check complete unit	13
2.2 Critical alarm function	5	5.2 Agency Approvals	14
2.3 Mounting	5	5.3 Specifications.....	15
2.4 Wiring.....	6	5.3.1 Physical.....	15
3.0 Switch Differential Adjustment	8	5.4 Replacement Parts	16
4.0 Preventive Maintenance		5.4.1 Model T20 Parts Identification.....	16
4.1 What to do.....	10	5.4.1.1 Model T20.....	17
4.1.1 Keep control clean	10	5.4.1.2 Mounting flanges	17
4.1.2 Inspect switch mechanisms, terminals, and connections monthly	10	5.4.1.3 Switch and housing reference	17
4.1.3 Inspect entire unit periodically.....	11	5.4.2 Model T21 Parts Identification.....	18
4.2 What to avoid	11	5.4.2.1 Model T21	19
		5.4.2.2 Mounting flanges and guide cage gaskets.....	19
		5.4.2.3 Switch and housing reference	19
		5.5 Model Numbers	20
		5.5.1 Model T20	20
		5.5.2 Model T21	22

1.0 Introduction

T20 and T21 level switches are float operated units designed for top mounting to a tank or vessel by means of threaded or flanged pipe connections. T20 standard units are equipped with a single switch mechanism for high or low level alarm or control applications. T21 tandem units are equipped with two switch mechanisms, each operated by a separate float, for applications requiring widely spaced separate high and low level switch actuation.

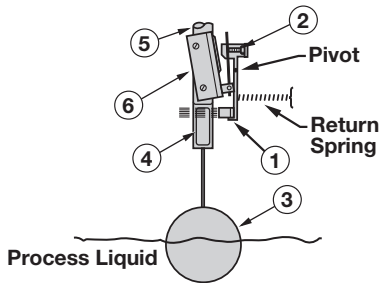

Rising Level

Figure 1

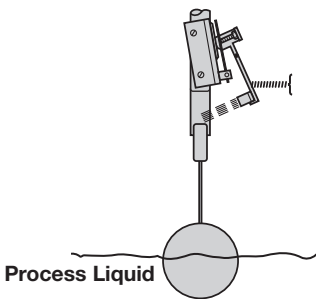

Falling Level

Figure 2

1.1 Principle of Operation

The simple and foolproof operation of the top mounted float switches is illustrated in figures 1 and 2.

A permanent magnet ① is attached to a pivoted switch actuator and adjustment screw ②. As the float ③ rises following the liquid level, it raises the attraction sleeve ④ into the field of the magnet, which then snaps against the non-magnetic enclosing tube ⑤, actuating the switch ⑥. The enclosing tube provides a static pressure boundary between the switch mechanism and the process. On a falling level, an Inconel spring retracts the magnet, deactivating the switch.

2.0 Installation

This section provides detailed procedures for properly installing top mounted level switches.

Caution: If equipment is used in a manner not specified by the manufacturer, protection provided by the equipment may be impaired.

2.1 Unpacking

Unpack the instrument carefully. Inspect all units for damage. Report any concealed damage to carrier within 24 hours. Check the contents of the packing slip against purchase order. Check and record the model number against serial number for future reference when ordering parts.

Model Number

Serial Number

2.2 Critical alarm function

It is recommended that for critical alarm functions, an additional level switch be installed as a high–high or low–low level alarm for maximum protection.

2.3 Mounting

Caution: Operation of all buoyancy type level devices should be done in such a way as to minimize the action of dynamic forces on the float or displacer sensing element. Good practice for reducing the likelihood of damage to the control is to equalize pressure across the device very slowly.

Ensure that no tubes, rods, or other obstacles in the tank or vessel which could interfere with the operation of float(s).

Caution: This instrument is intended for use in Installation Category II, Pollution Degree 2.

Adjust the process connection as required to bring control to a vertical position. MAGNETROL controls must be mounted within three degrees of vertical in all directions. A three degree slant is noticeable by eye, but installation should be checked with a spirit level on top and/or sides of float stem or enclosing tube.

NOTE: Do not insulate switch mechanism housing.

On controls equipped with pneumatic switch assemblies, consult bulletin on mechanism furnished for air (or gas) piping instructions.

Switch Series Letter	Description	Bulletin No.
B, C, D	Dry Contact Switch	42-683
F	Hermetically Sealed Snap Switch	
HS	Hermetically Sealed Snap Switch	42-694
J	Bleed Type Pneumatic Switch	42-685
K	Non-Bleed Type Pneumatic Switch	42-686
R, 8, 9	High Temperature Switch	42-799

2.4 Wiring

Caution: All Top Mounting units are shipped from the factory with the enclosing tube tightened and the switch housing set screw locked to the enclosing tube. Failure to loosen the set screw prior to repositioning the supply and output connections may cause the enclosing tube to loosen, resulting in possible leakage of the process liquid or vapor.

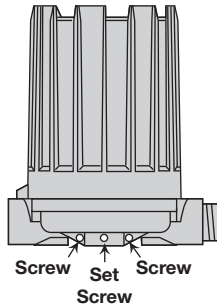

Figure 3
Housing Set Screws

Top mounting controls are shipped with the conduit entry of the switch housing placed 180° opposite the tank connections to simplify installation in most cases. If the location of the conduit entry on the level switch is appropriate to the installation, proceed to Step 4 to begin wiring the unit. If another configuration is desired, the switch housing can be easily rotated by first following Steps 1, 2, and 3.

NOTE: A switch or circuit breaker shall be installed in close proximity to equipment and within easy reach of operator. It shall be marked as the disconnecting device for the equipment.

1. Loosen set screw(s) at base of switch housing. Refer to Figure 3.
2. Switch housing may be rotated 360° to allow correct positioning of conduit outlet.
3. Tighten set screw(s) at base of switch housing.
4. Unscrew and remove switch housing cover. The threads have been lubricated to facilitate removal.

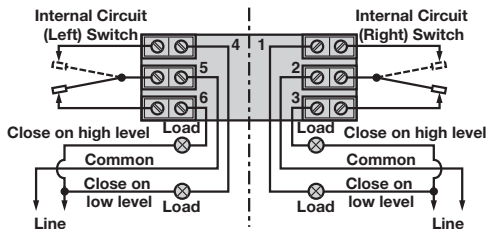

Figure 4
Terminal Connections
DPDT Switch Mechanism
Series B, C, and D

NOTE: For supply connections use wire with a minimum rating of 75 °C, as required by process conditions. Use a minimum of 14 AWG wire for power and ground field wires. On high temperature applications (above 250 °F [121 °C] at mounting flange or bushing), high temperature wire should be used between control and first junction box located in a cooler area. On non-hazardous applications, flexible conduit may be used between the control and the first junction box.

5. The switch terminals are located next to the conduit outlet to facilitate wiring. Bring supply wires through conduit outlet. Route extra wire around enclosing tube under the baffle plate, and connect them to the proper terminals. Refer to the wiring diagram, Figure 4, or your switch bulletin for this information.

-
6. Dress wiring to ensure no interference or contact with the switch actuation arm, or replacement of switch housing cover.

NOTE: Observe all applicable electrical codes and proper wiring procedures.

Prevent moisture seepage into the enclosure by installing approved seal-drain fittings in the conduit run leading into the unit.

Caution: In hazardous areas, do not power the unit until the conduit is sealed and the enclosure cover is screwed down securely.

7. Replace housing cover.
8. If control has been furnished with an explosion proof or moisture proof switch housing, it must be sealed at the conduit outlet with a suitable compound or non-hardening sealant to prevent entrance of air.
9. Test switch action by varying liquid level in the tank or vessel. The upper switch on Model T21 units is actuated by movement of the lower float, while the lower switch is actuated by the upper float.

NOTE: If switch mechanism fails to function properly, check vertical alignment of control housing and consult installation bulletin on switch mechanism furnished.

10. Check cover to base fit to be certain gasketed joint is tight. A positive seal is necessary to prevent infiltration of moisture laden air or corrosive gasses into switch housing.

3.0 Switch Differential Adjustment

The standard differential of the single float Model T20 may be field adjusted. Adjustment may be necessary if a wider differential needs to be set to overcome switch chatter caused by the process.

The differential, or the amount of level travel between switch-on and switch-off, may be adjusted by repositioning the lower jam nuts on the float stem. The standard factory setting is for a minimum amount of play (gap) between the top jam nuts and the attraction sleeve as shown in Figure 6.

NOTE: For assistance in computing level differential change for a specific control, consult the factory giving the model and serial numbers of the control.

Caution: Maximum differential adjustment is 0.50 inch.

NOTE: To widen the differential 0.50 inch, the lower jam nuts must be set proportionately lower on the stem (i.e., in this example 0.50 inch).

Caution: Before attempting any work on the control, pull disconnect switch, or otherwise assure that electrical circuit(s) through the control is deactivated. Close operating medium supply valve on controls equipped with pneumatic switch mechanisms.

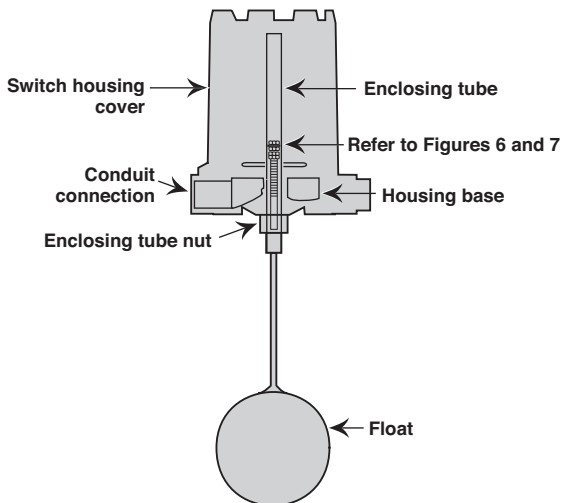

Figure 5

1. Determine what change in differential is necessary.
2. Make sure power source is turned off.
3. Unscrew and remove switch housing cover.
4. Disconnect power supply wires from switch mechanism. Pull wires out of conduit connection opening in housing base. Refer to Figure 5.
5. Perform system shut-down procedures as required to relieve pressure from tank or vessel and drain off liquid head, if required. Allow unit to cool.

NOTE: The amount of level travel between switch-on and switch-off actuation (differential) may be field adjusted by repositioning the lower jam nuts on the float stem. The standard factory setting is for a minimum amount of play (gap) between the top jam nuts and the attraction sleeve, as shown in Figure 6. This setting may be increased to a maximum of 0.50" (13 mm), as shown in Figure 7.

6. Remove switch housing assembly by loosening the enclosing tube nut, which is located immediately below housing base. Refer to Figure 5.

7. With switch housing and enclosing tube removed, jam nuts and attraction sleeve are accessible. Measure position of upper jam nuts from stem end; then loosen and remove upper jam nuts, guide washer, and attraction sleeve.
8. Loosen and adjust lower jam nuts to desired position. Make certain jam nuts are retightened securely.

NOTE: Use new enclosing tube gasket in assembly of switch housing to the mounting bushing or flange. Refer to **Sections 5.4.1.1** and **5.4.2.1** for enclosing tube gasket part numbers.

9. Test switch actuation by varying liquid level in tank or vessel.

Caution: Instructions given are for standard base model units which use a single magnet switch mechanism only. No differential adjustment should be attempted on tandem float models in the field. Switch actuation levels have been set at the factory to meet specific customer specifications. Variations in actual conditions from design conditions usually requires special control modifications. Consult with the factory or local representative for assistance.

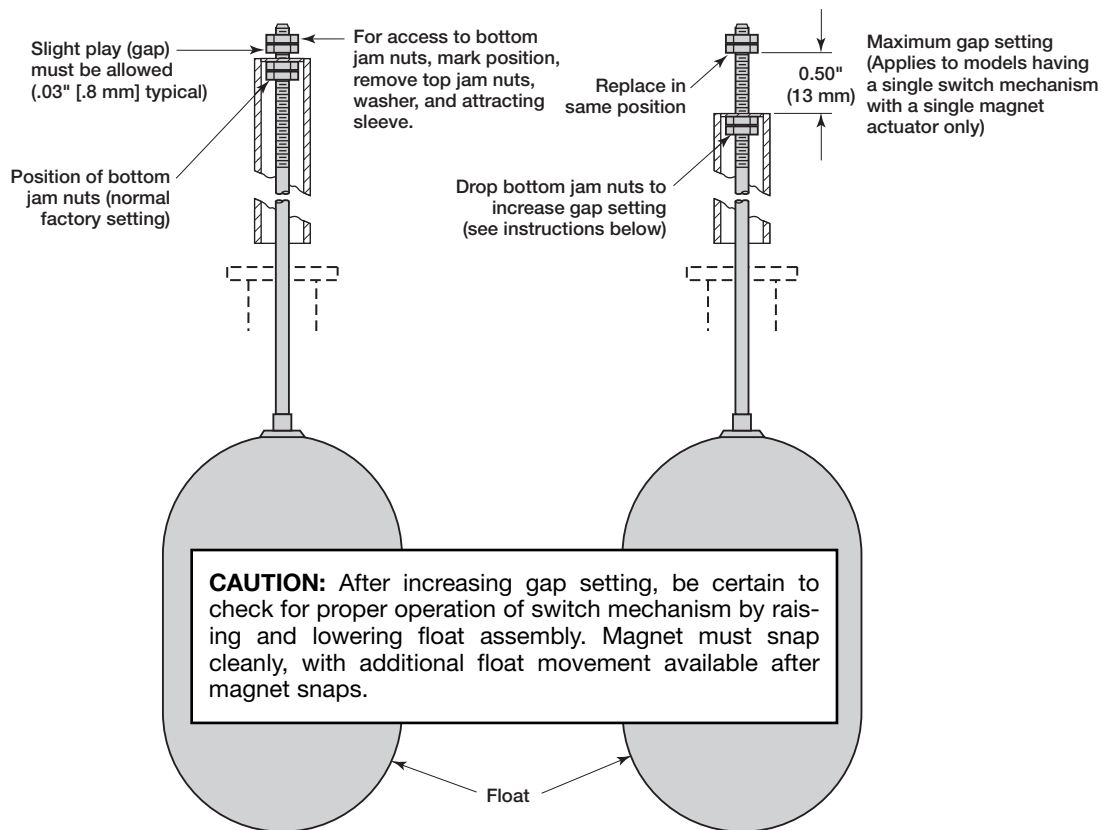

Figure 6
Normal Factory Setting
(minimum differential)

Figure 7
Differential
adjustment

4.0 Preventive Maintenance

Periodic inspections are a necessary means to keep your level control in good working order. This control is a safety device to protect the valuable equipment it serves. Therefore, a systematic program of “preventive maintenance” must be implemented when the control is placed into service. If the following sections on “what to do” and “what to avoid” are observed, your control will provide reliable protection of your equipment for many years.

4.1 What to do

4.1.1 Keep control clean

Be sure the switch housing cover is always in place on the control. This cover is designed to keep dust and dirt from interfering with switch mechanism operation. In addition, it protects against damaging moisture and acts as a safety feature by keeping bare wires and terminals from being exposed. Should the housing cover or any seals become damaged or misplaced, obtain a replacement immediately.

4.1.2 Inspect switch mechanisms, terminals, and connections monthly

1. Switches should be inspected for excessive wear on actuating lever or misalignment of adjustment screw at point of contact between screw and lever. Such wear can cause false switch actuating levels. See switch mechanism bulletin supplied with control should switch adjustment or replacement be necessary.
2. DO NOT operate your control with defective or mal-adjusted switch mechanisms (refer to bulletin on switch mechanisms furnished for service instructions.)
3. Level controls may sometimes be exposed to excessive heat or moisture. Under such conditions, insulation on electrical wiring may become brittle, eventually breaking or peeling away. The resulting “bare” wires can cause short circuits.

NOTE: Check wiring carefully and replace at the first sign of brittle insulation.

4. Vibration may sometimes cause terminal screws to work loose. Check all terminal connections to be certain that screws are tight.

-
5. On units with pneumatic switches, air (or gas) lines subjected to vibration, may eventually crack or become loose at connections causing leakage. Check lines and connections carefully and repair or replace, if necessary.

NOTE: As a matter of good practice, spare switches should be kept on hand at all times.

4.1.3 Inspect entire unit periodically

Isolate control from vessel. Raise and lower liquid level to check for switch contact and reset.

4.2 What to avoid

1. Never leave switch housing cover off the control longer than necessary to make routine inspections.
2. Never place a jumper wire across terminals to “cut-out” the control. If a “jumper” is necessary for test purposes, be certain it is removed before placing control into service.
3. Never attempt to make adjustments or replace switches without reading instructions carefully. Certain adjustments provided for in level controls should not be attempted in the field. When in doubt, consult the factory or your local representative.
4. Never use lubricants on pivots of switch mechanisms. A sufficient amount of lubricant has been applied at the factory to ensure a lifetime of service. Further oiling is unnecessary and will only tend to attract dust and dirt which can interfere with mechanism operation.

5.0 Reference Information

5.1 Troubleshooting

Usually the first indication of improper operation is failure of the controlled equipment to function, (i.e.: pump will not start (or stop), signal lamps fail to light, etc.) When these symptoms occur, whether at time of installation or during routine service thereafter, check the following potential external causes first.

- a. Fuses may be blown.
- b. Reset button(s) may need resetting.
- c. Power switch may be open.
- d. Controlled equipment may be faulty.
- e. Wiring leading to control may be defective.

If a thorough inspection of these possible conditions fails to locate the trouble, proceed next to a check of the control's switch mechanism.

5.1.1 Check switch mechanism

1. Pull disconnect switch or otherwise disconnect power to the control.
2. Remove switch housing cover.
3. Disconnect power wiring from switch assembly.
4. Swing magnet assembly in and out by hand to check carefully for any sign of binding. Assembly should require minimal force to move it through its full swing.
5. If binding exists, magnet may be rubbing enclosing tube. If magnet is rubbing, loosen magnet clamp screw and shift magnet position. Retighten magnet clamp screw.
6. If switch magnet assembly swings freely and mechanism still fails to actuate, check installation of control to be certain it is within the specified three degrees of vertical. (Use spirit level on side of enclosing tube in two places, 90° apart.
7. Check the continuity of the microswitch with ohmmeter. Replace immediately if found defective.
8. If switch mechanism is operating satisfactorily, proceed to check sensing unit.

5.1.2 Check complete unit

1. Reconnect power supply and carefully actuate switch mechanism manually (using a non-conductive tool) to determine whether controlled equipment will operate.

Caution: With electrical power on, care should be taken to avoid contact with switch leads and connections at terminal block.

2. If controlled equipment responds to manual actuation test, trouble may be located in the level sensing portion of the control–float(s), stem(s), and magnetic attraction sleeve(s).

NOTE: Ensure that liquid is entering the storage tank or vessel. A valve may be closed or a pipe line plugged.

Caution: Be certain to pull disconnect switch or otherwise ensure that electrical circuit(s) through control is deactivated. Close operating medium supply valve on controls equipped with pneumatic switch mechanisms.

3. With liquid in tank or vessel, raise the liquid level above the set points. Magnets should “pull-in” on rising level. On Model T21 the lower float actuates the upper switch, and the upper float actuates the lower switch. If magnets fail to “pull-in”, lower the level and purge pressure.
 - a. Disconnect wiring from supply side of switch mechanism(s) and remove electrical conduit or operating medium line connections to switch housing.
 - b. Remove switch housing assembly by loosening hex nut, which is located immediately below housing base.
4. With switch housing assembly removed, inspect attraction sleeve(s) and inside of enclosing tube for excessive corrosion or solids buildup, which could restrict movement, preventing sleeve(s) from reaching field of switch magnet(s).
5. If differential has been changed in the field by repositioning the lower jam nuts on the float stem, check tightness and position of the jam nuts. Refer to Figure 6.





NOTE: Differential adjustment affects a change in the amount of level travel between switch-on and switch-off actuation. Do not attempt adjustment without first consulting factory for assistance in computing level differential change for your control.

6. Check float to be certain it is buoyant in the liquid (tank or vessel must have adequate liquid level). If float is determined to be filled with liquid, or it is collapsed, it must be replaced immediately. Do not attempt to repair a float.

If all components in the control are in operating condition, the trouble must be (and should be) located external to the control. Repeat inspection of external conditions previously described.

When communicating about your control, be certain to always specify the complete Model and Serial numbers.

5.2 Agency Approvals

AGENCY	MODEL APPROVED	APPROVAL CLASSES
FM 	All with an electric switch mechanism and a housing listed as TYPE 4X/7/9	Class I, Div 1, Groups C & D Class II, Div 1, Groups E, F & G
	All with an electric switch mechanism and a housing listed as TYPE 4X/7/9 Class I, Div 1, Group B	Class I, Div 1, Groups B, C & D Class II, Div 1, Groups E, F & G
CSA 	All with a Series HS, F, 8 or 9 electric switch mechanism and a housing listed as CSA TYPE 4X	Class I, Div 2, Groups A, B, C & D
	All with an electric switch mechanism and a housing listed as TYPE 4X/7/9	Class I, Div 1, Groups C & D Class II, Div 1, Groups E, F & G
	All with an electric switch mechanism and a housing listed as TYPE 4X/7/9 Class I, Div 1, Group B	Class I, Div 1, Groups B, C & D Class II, Div 1, Groups E, F & G
ATEX / IEC Ex ② 	All with an electric switch mechanism and an ATEX housing ①	ATEX II 2 G EEx d IIC T6 94/9/EC IEC Ex Ex d IIC T6 IP 66
CE 	Low Voltage Directives 2006/95/EC Per Harmonized Standard: EN 61010-1/1993 & Amendment No. 1	Installation Category II Pollution Degree 2

① Dual stage units with 'HS' switches are not ATEX approved.

② IEC Installation Instructions:

The cable entry and closing devices shall be Ex d certified suitable for the conditions of use and correctly installed.

For ambient temperatures above +55 °C or for process temperatures above +150 °C, suitable heat resistant cables shall be used.

Heat extensions (between process connection and housing) shall never be insulated.

Special conditions for safe use:

When the equipment is installed in process temperatures higher than +85 °C the temperature classification must be reduced according to the following table as per IEC60079-0.

Maximum Process Temperature	Temperature Classification
< 85 °C	T6
< 100 °C	T5
< 135 °C	T4
< 200 °C	T3
< 300 °C	T2
< 450 °C	T1

These units are in conformity with IECEx KEM 05.0020X
Classification Ex d IIC T6
T_{ambient} -40 °C to +70 °C

5.3 Specifications

5.3.1 Physical inches (mm)

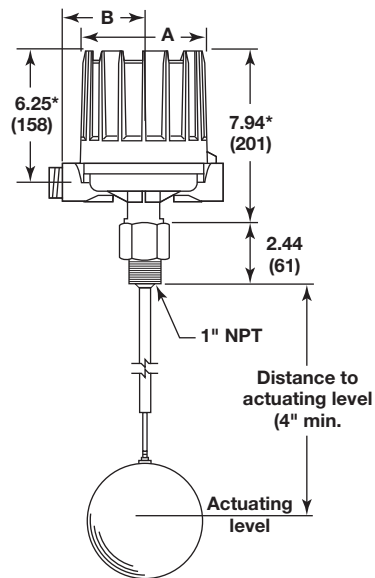

Model T20 with 1" NPT

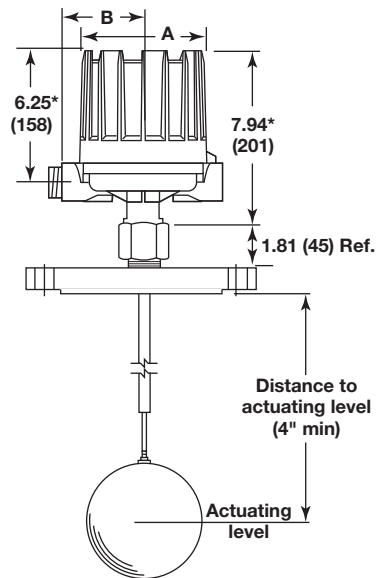

Model T20 with flange

* These dimensions increase by 2.19 (55) when unit is supplied with an HS switch with terminal block.

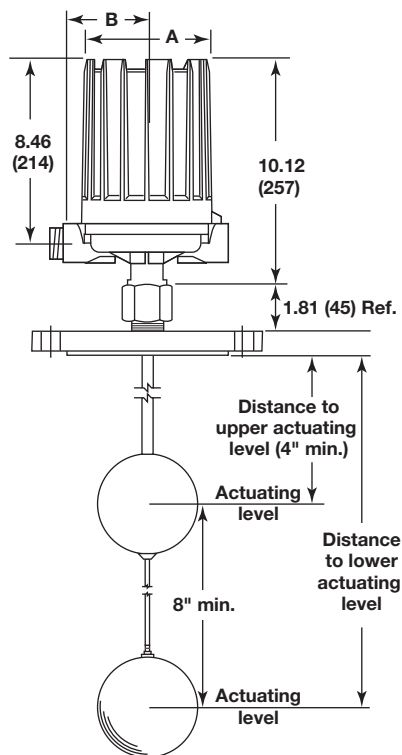

Model T21 with flange

Housing ①	A	B	Conduit Connections
TYPE 4X/7/9, Group B	5.93 (151)	3.87 (98)	1" NPT dual entry
NEMA 1 ② Pneumatics	4.70 (119)	5.00 (127)	1/4" NPT single entry

① All housings rotatable 360°.

② Pneumatic switches available with Series T20 units only.

Distance To	Maximum	Minimum
Upper level	40" (1016)	4" (102)
Lower level	48" (1219)	12" (305)

NOTE: On Model T21 the lower float actuates upper switch mechanism. The upper float actuates the lower switch mechanism.

5.4 Replacement Parts

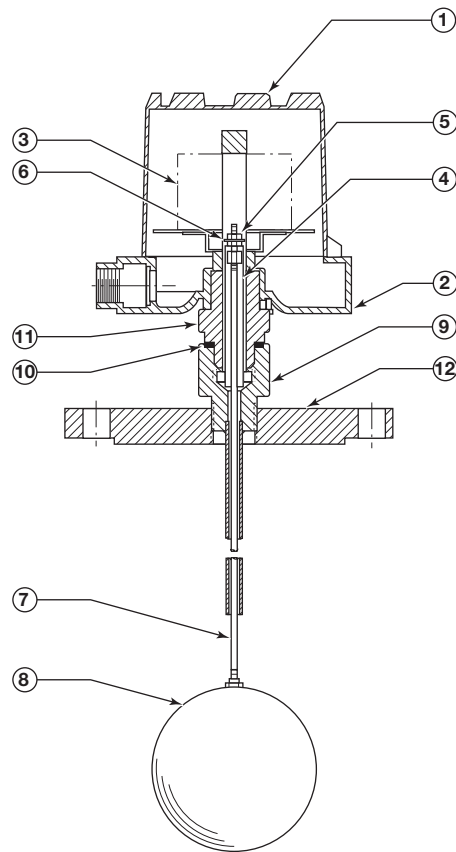

5.4.1 Model T20 Parts Identification

Item	Description
1	Housing cover
2	Housing base
3	Switch mechanism
4	Attraction sleeve
5	Jam nuts
6	Guide washer(s)
7	Float stem
8	Float
9	Adaptor bushing/guide tube assembly
10	Enclosing tube gasket
11	Enclosing tube
12	Mounting flange

5.4.1.1 Model T20

	T20-1	T20-4
Housing cover	See below	
Housing base	See below	
Switch mechanism	See below	
Stem kit: includes items 4, 5, 6, & 7	Consult factory	
Float: 3.00" × 5.00"	Z07-1202-003	
3.50" × 6.00"	Z07-1202-009	
4.00"	Z07-1102-008	
4.50"	Z07-1102-009	
Adaptor bushing/guide tube assembly	Consult factory	
Float stem	Consult factory	
Enclosing tube gasket	012-1301-002	
Enclosing tube	Z32-6325-001	Z32-6325-002
Mounting flange	See below	

5.4.1.2 Mounting flanges

	125 lb cast iron	150 lb forged steel	300 lb forged steel	150 lb forged 304	150 lb forged 316
4" flange	Z04-5840-001	Z04-5840-011	Z04-5840-016	004-5840-021	004-5840-026
5" flange	Z04-5840-002	Z04-5840-012	Z04-5840-017	004-5840-022	004-5840-027
6" flange	Z04-5840-003	Z04-5840-013	Z04-5840-018	004-5840-023	004-5840-028
8" flange	Z04-5840-004	Z04-5840-014	Z04-5840-019	004-5840-024	004-5840-029

5.4.1.3 Switch and housing reference

	Series Type	Bulletin#
Dry contact	B, C, D	42-683
Hermetically sealed	F	42-683
Hermetically sealed	HS	42-694
Bleed type pneumatic	J	42-685
Non-bleed type pneumatic	K	42-486
High Temperature	R, 8, 9	42-799

Important: When ordering spare parts, please specify:

- A. Model and serial numbers.
- B. Name and part number of replacement part or assembly.

All replacement parts are for standard models only. Consult your local representative for ordering assistance on all specially modified models (model numbers preceded by an X).

5.4 Replacement Parts

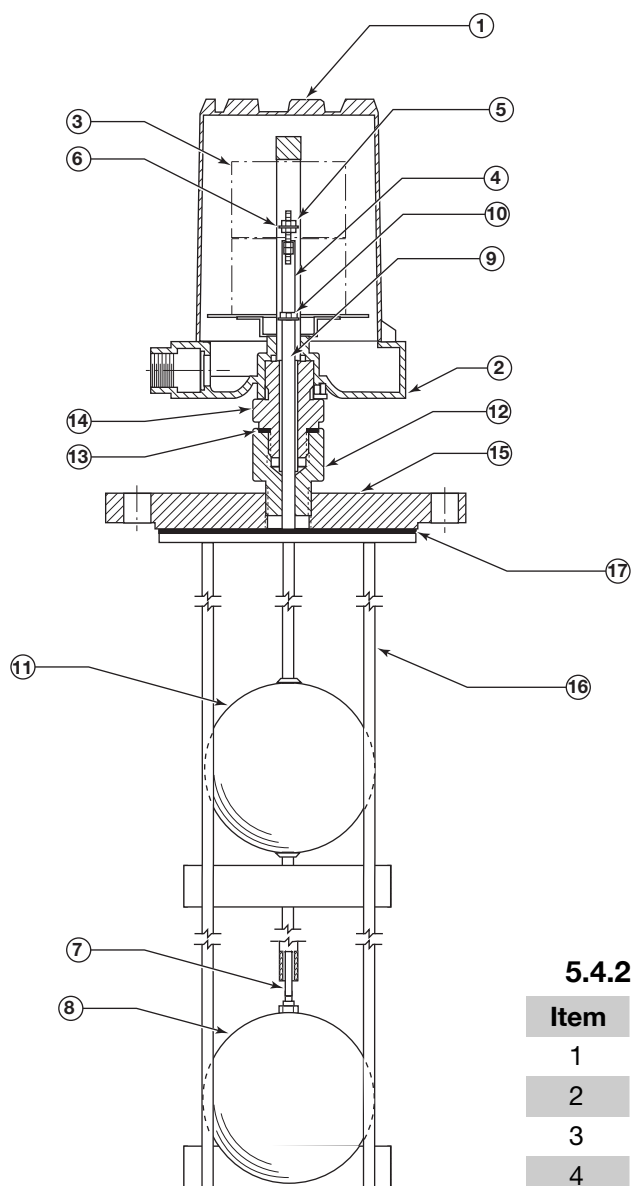

5.4.2 Model T21 Parts Identification

Item	Description
1	Housing cover
2	Housing base
3	Switch mechanism
4	Upper attraction sleeve
5	Jam nuts
6	Guide washer(s)
7	Upper stem assembly
8	Lower float
9	Lower attraction sleeve, stop tube, and washers
10	Retaining rings
11	Upper float and tube assembly
12	Adaptor bushing
13	Enclosing tube gasket
14	Enclosing tube
15	Mounting flange
16	Float guide cage (optional)
17	Float guide cage gasket (optional)

5.4.2.1 Model T21

	T21-1	T21-4
Housing cover	See below	
Housing base	See below	
Switch mechanism	See below	
Float stem kit: includes items 4, 5, 6, & 7	Consult factory	
Lower float: 3" x 5"	Z07-1201-003	Z07-1202-003
4.00"	Z07-1101-015	Z07-1102-008
4.50"	Z07-1102-009	
Upper float and tube assembly kit: includes items 9, 10, & 11	Consult factory	
Adaptor bushing	Z04-5734-110	004-5734-123
Enclosing tube gasket	012-1301-002	
Enclosing tube	Z32-6325-004	Z32-6325-005
Mounting flange	See below	
Guide cage kits: includes items 16 & 17	Consult factory	

5.4.2.2 Mounting flanges

	125 lb cast iron	150 lb forged steel	300 lb forged steel	150 lb forged 304	150 lb forged 316
4" flange	Z04-5840-001	Z04-5840-011	Z04-5840-016	004-5840-021	004-5840-026
5" flange	Z04-5840-002	Z04-5840-012	Z04-5840-017	004-5840-022	004-5840-027
6" flange	Z04-5840-003	Z04-5840-013	Z04-5840-018	004-5840-023	004-5840-028
8" flange	Z04-5840-004	Z04-5840-014	Z04-5840-019	004-5840-024	004-5840-029

5.4.2.3 Switch and housing reference

	Series Type	Bulletin#
Dry contact	B, C, D	42-683
Hermetically sealed	F	42-683
Hermetically sealed	HS	42-694
Bleed type pneumatic	J	42-685
Non-bleed type pneumatic	K	42-486
High Temperature Snap	R, 8, 9	42-799

Important: When ordering spare parts, please specify:

- A. Model and serial numbers.
- B. Name and part number of replacement part or assembly.

All replacement parts are for standard models only. Consult your local representative for ordering assistance on all specially modified models (model numbers preceded by an X).

5.5 Model Numbers

5.5.1 Model T20

IMPORTANT: Actuating level(s), in either the rising or falling state, and specific gravity must be provided upon placement of order.

MODEL NUMBER CODE AND MATERIALS OF CONSTRUCTION

Model No.	Set Points	Tank Connection	Float and Trim	Sleeve
T20-1	1—Single float	Carbon steel	300 Series SS	400 Series SS
T20-4		316 SS	316 SS	316 SS

IMPORTANT: The maximum available insertion depth is governed by the liquid specific gravity and selected float size as given in the table below. The minimum insertion depth is four inches.

MAXIMUM INSERTION LENGTH inches (mm)

Liquid Specific Gravity	Float Size		
	3.00 x 5.00 (76 x 127)	4.00 (102)	4.50 (114)
1.00	39 (991)	48 (1219)	48 (1219)
0.90	20 (508)	33 (838)	48 (1219)
0.80	—	11 (279)	48 (1219)
0.70	—	—	38 (965)
0.60	—	—	6 (152)

FLOAT PRESSURE RATINGS

Float Size Inches (mm)	Pressure Rating PSIG (bar)			
	100 °F (38 °C)	750 °F (399 °C)	900 °F (482 °C)	1000 °F (538 °C)
3.00 x 5.00 (76 x 127)	500 (34)	377 (26)	353 (24)	335 (23)
4.00 (102)	600 (41)	483 (33)	465 (32)	459 (32)
3.50 x 6.00 (89 x 152)	500 (34)	403 (27)	388 (26)	383 (26)
4.50 (114)	500 (34)	403 (28)	388 (27)	383 (26)

TANK CONNECTION AND FLOAT SIZE

Tank Connection ①	Float Diameter			
	3.00 x 5.00 (76 x 127)	4.00 (102)	4.50 (114)	3.50 x 6.00 (89 x 152)⑤
1" NPT	B2A	B2B	B2C	B2D
4" 125 lb. C.I. flange ② ③	H2A	—	—	H2D
4" 150 lb. F.S. flange	H3A	—	—	H3D
4" 300 lb. F.S. flange	H4A	—	—	H4D
5" 125 lb. C.I. flange ② ③	J2A	J2B	J2C	J2D
5" 150 lb. F.S. flange	J3A	J3B	J3C	J3D
5" 300 lb. F.S. flange	J4A	J4B	J4C	J4D
6" 125 lb. C.I. flange ② ③	K2A	K2B	K2C	K2D
6" 150 lb. F.S. flange	K3A	K3B	K3C	K3D
6" 300 lb. F.S. flange	K4A	K4B	K4C	K4D
8" 150 lb. F.S. flange	L3A	L3B	L3C	—

- ① Flanges are ANSI standard threaded onto 1" NPT bushing. Forged steel flanges have standard raised face.
- ② Not available with Model T20-4.
- ③ Available only in cast iron.
- ④ Process temperature based on +100 °F (+38 °C) ambient.
- ⑤ Uncontrolled housing heater or drain available in TYPE 4X/7/9 enclosure.
- ⑥ Consult factory for TYPE 4X/7/9 cast iron housings.
- ⑦ On steam applications, temperature down-rated to +400 °F (+204 °C) process at +100 °F (+38 °C) ambient.
- ⑧ CSA approval does not apply to Series HE switches.
- ⑨ Not available when 4" nozzle is sch 160 or greater.



Switch Description	Process ④ Temperature Range °F (°C)	Contacts	Set Points	T20-1 Models			T20-4 Models		
				TYPE 4X/7/9 Aluminum Enclosure ⑤⑥					
				Class I, Div 1 Groups C&D	Class I, Div 1 Group B	ATEX Ex II 2 G EEx d IIC T6	Class I, Div 1 Groups C&D	Class I, Div 1 Group B	ATEX Ex II 2 G EEx d IIC T6
Series B Snap Switch	-40 to +250 (-40 to +121)	SPDT	1	BKP	BKT	BAC	BKQ	BKS	BA9
		DPDT	1	BNP	BNT	BBC	BNQ	BNS	BB9
Series C Snap Switch	-40 to +450 (-40 to +232)	SPDT	1	CKP	CKT	CAC	CKQ	CKS	CA9
		DPDT	1	CNP	CNT	CBC	CNQ	CNS	CB9
Series D DC Current Snap Switch	-40 to +250 (-40 to +121)	SPDT	1	DKQ	DKS	DA9	DKQ	DKS	DA9
		DPDT	1	DNQ	DNS	DB9	DNQ	DNS	DB9
Series F Hermetically Sealed Snap Switch	-50 to +750 (-46 to +399)	SPDT	1	FKP	FKT	FAC	FKQ	FSS	FA9
		DPDT	1	FNP	FNT	FBC	FNQ	FNS	FB9
Series HS Hermetically Sealed 5-amp Snap Switch with Wiring Leads	-50 to +550 ⑦ (-46 to +288)	SPDT	1	HMC	HEK ⑧	—	HMC	HEK ⑧	—
		DPDT	1	HMF	HET ⑧		HMF	HET ⑧	
Series HS Hermetically Sealed 5-amp Snap Switch with Terminal Block	-50 to +550 ⑦ (-46 to +288)	SPDT	1	HM3	HM4	HA9	HM3	HM4	HA9
		DPDT	1	HM7	HM8	HB9	HM7	HM8	HB9
Series R High Temperature Snap Switch	-40 to +750 (-40 to +399)	SPDT	1	RKQ	RKS	RA9	RKQ	RKS	RA9
		DPDT	1	RNQ	RNS	RB9	RNQ	RNS	RB9
Series 8 Hermetically Sealed Snap Switch	-50 to +750 (-46 to +399)	SPDT	1	8KP	8KT	8AC	8KQ	8KS	8A9
		DPDT	1	8NP	8NT	8BC	8NQ	8NS	8B9
Series 9 High Temperature Hermetically Sealed Snap Switch	-50 to +750 (-46 to +399)	SPDT	1	9KP	9KT	9AC	9KQ	9KS	9A9
		DPDT	1	9NP	9NT	9BC	9NQ	9NS	9B9
Switch Description	Process ④ Temp. Range °F (°C)	Contacts	Set Points	CS/Aluminum	Cast Iron		CS/Aluminum	Cast Iron	
				NEMA 4X	Class I, Div 1 Groups C&D	Class I, Div 1 Group B	NEMA 4X	Class I, Div 1 Groups C&D	Class I, Div 1 Group B
Series R High Temperature Snap Switch	-40 to +1000 (-40 to +538)	SPDT	1	R1Y	RKY	RKW	R1Y	RKY	RKW
		DPDT	1	RDY	RNY	RNW	RDY	RNY	RNW
Series 9 High Temperature Hermetically Sealed Snap Switch	-50 to +1000 (-46 to +538)	SPDT	1	9AR	9KR	9KV	9AY	9KY	9KW
		DPDT	1	9DR	9NR	9NV	9DY	9NY	9NW

PNEUMATIC SWITCH MECHANISM AND ENCLOSURE

Switch Description	Maximum Supply Pressure	Maximum Process Temperature	Bleed Orifice Diameter	NEMA 1
Series J Bleed Type	100 psig (7 bar)	400 °F (204 °C)	.063 (1.6 mm)	JDE
	60 psig (4 bar)		.094 (2.4 mm)	JEE
	60 psig (4 bar)	700 °F (371 °C)	.055 (1.4 mm)	JFE
Series K Non-Bleed	100 psig (7 bar)	400 °F (204 °C)	—	KOE
	40 psig (3 bar)		—	KOG

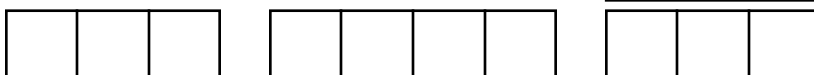

5.5 Model Numbers

5.5.2 Model T21

IMPORTANT: Actuating level(s), in either the rising or falling state, and specific gravity must be provided upon placement of order.

MODEL NUMBER CODE AND MATERIALS OF CONSTRUCTION

Model No.	Set Points	Tank Connection	Float and Trim	Sleeve
T21-1	2—Tandem float	Carbon steel	300 Series SS	400 Series SS
T21-4		316 SS	316 SS	316 SS

IMPORTANT: The maximum available insertion depth is governed by the liquid specific gravity and selected float size as given in the table below. The minimum insertion depth is four inches. The minimum distance between the top and bottom insertion depths is eight inches.

MAXIMUM INSERTION LENGTH inches (mm)

Liquid Specific Gravity	Float Size					
	3.00 x 5.00 (76 x 127)		4.00 (102)		4.50 (114)	
	Upper	Lower	Upper	Lower	Upper	Lower
1.00	21 (533)	48 (1219)	32 (813)	48 (1219)	40 (1016)	48 (1219)
0.90	9 (229)	30 (762)	18 (457)	44 (1118)	40 (1016)	48 (1219)
0.80	—	—	4 (102)	21 (533)	40 (1016)	48 (1219)
0.70	—	—	—	—	21 (533)	48 (1219)

FLOAT PRESSURE RATINGS

Float Size Inches (mm)	Pressure Rating PSIG (bar)			
	100 °F (38 °C)	750 °F (399 °C)	900 °F (482 °C)	1000 °F (538 °C)
3.00 x 5.00 (76 x 127)	500 (34)	377 (26)	353 (24)	335 (23)
4.00 (102)	600 (41)	483 (33)	465 (32)	459 (32)
4.50 (114)	500 (34)	403 (28)	388 (27)	383 (26)

TANK CONNECTION AND FLOAT SIZE

Tank Connection ①	Float Diameter		
	3.00 x 5.00 (76 x 127)	4.00 (102)	4.50 (114)
4" 125 lb. C.I. flange ② ③	H2A	—	—
4" 150 lb. F.S. flange	H3A	—	—
5" 125 lb. C.I. flange ② ③	J2A	J2B	J2C
5" 150 lb. F.S. flange	J3A	J3B	J3C
6" 125 lb. C.I. flange ② ③	K2A	K2B	K2C
6" 150 lb. F.S. flange	K3A	K3B	K3C
6" 300 lb. F.S. flange	—	—	K4C
8" 150 lb. F.S. flange	L3A	L3B	L3C

- ① Flanges are ANSI standard. Forged steel flanges have standard raised face.
- ② Not available with -4 Materials of Construction.
- ③ Available only in cast iron.
- ④ Process temperature based on +100 °F (+38 °C) ambient.
- ⑤ Uncontrolled housing heater or drain available in TYPE 4X/7/9 enclosure.
- ⑥ Consult factory for TYPE 4X/7/9 cast iron housings.
- ⑦ On steam applications, temperature down-rated to +400 °F (+204 °C) process at +100 °F (+38 °C) ambient.



ELECTRIC SWITCH MECHANISM AND ENCLOSURE

Switch Description	Process ④ Temperature Range °F (°C)	Contacts	Set Points	T21-1 Models			T21-4 Models		
				TYPE 4X/7/9 Aluminum Enclosure ⑤⑥					
				Class I, Div 1 Groups C&D	Class I, Div 1 Group B	ATEX Ex II 2 G EEx d IIC T6	Class I, Div 1 Groups C&D	Class I, Div 1 Group B	ATEX Ex II 2 G EEx d IIC T6
Series B Snap Switch	-40 to +250 (-40 to +121)	SPDT	2	BLA	BLJ	BDC	BLB	BLK	BD9
		DPDT	2	BOA	BOJ	BGC	BOB	BOK	BG9
Series C Snap Switch	-40 to +450 (-40 to +232)	SPDT	2	CLA	CLJ	CDC	CLB	CLK	CD9
		DPDT	2	COA	COJ	CGC	COB	COK	CG9
Series D DC Current Snap Switch	-40 to +250 (-40 to +121)	SPDT	2	DLB	DLK	DD9	DLB	DLK	DD9
		DPDT	2	DOB	DOK	DG9	DOB	DOK	DG9
Series F Hermetically Sealed Snap Switch	-50 to +750 (-46 to +399)	SPDT	2	FLA	FLJ	FDC	FLB	FLK	FD9
		DPDT	2	FOA	FOJ	FGC	FOB	FOK	FG9
Series HS Hermetically Sealed 5-amp Snap Switch with Wiring Leads	-50 to +550 ⑦ (-46 to +288)	SPDT	2	HMN	HMP	—	HMN	HMP	—
		DPDT	2	HMY	HMZ		HMY	HMZ	
Series R High Temperature Snap Switch	-40 to +750 (-40 to +399)	SPDT	2	RLB	RLK	RD9	RLB	RLK	RD9
		DPDT	2	ROB	ROK	RG9	ROB	ROK	RG9
Series 8 Hermetically Sealed Snap Switch	-50 to +750 (-46 to +399)	SPDT	2	8LA	8LJ	8DC	8LB	8LK	8D9
		DPDT	2	8OA	8OJ	8GC	8OB	8OK	8G9
Series 9 High Temperature Hermetically Sealed Snap Switch	-50 to +750 (-46 to +399)	SPDT	2	9LA	9LJ	9DC	9LB	9LK	9D9
		DPDT	2	9OA	9OJ	9GC	9OB	9OK	9G9
Switch Description	Process ④ Temp. Range °F (°C)	Contacts	Set Points	CS/Aluminum	Cast Iron		CS/Aluminum	Cast Iron	
				NEMA 4X	Class I, Div 1 Groups C&D	Class I, Div 1 Group B	NEMA 4X	Class I, Div 1 Groups C&D	Class I, Div 1 Group B
Series R High Temperature Snap Switch	-40 to +1000 (-40 to +538)	SPDT	2	R3M	RLM	RLW	R3M	RLM	RLW
		DPDT	2	REM	ROM	ROW	REM	ROM	ROW
Series 9 High Temperature Hermetically Sealed Snap Switch	-50 to +1000 (-46 to +538)	SPDT	2	9BD	9LD	9LV	9BM	9LM	9LW
		DPDT	2	9ED	9OD	9OV	9EM	9OM	9OW

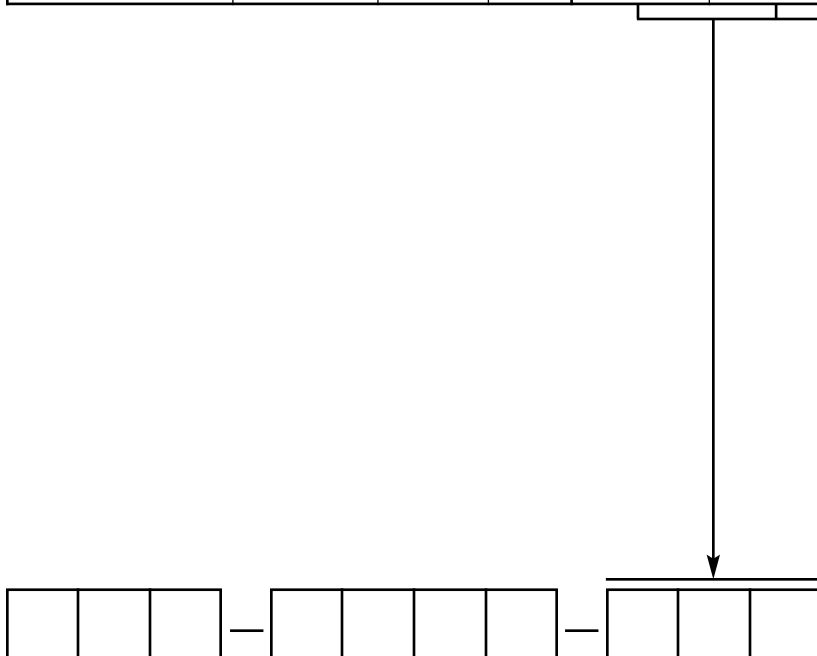

Service Policy

Owners of MAGNETROL may request the return of a control or any part of a control for complete rebuilding or replacement. They will be rebuilt or replaced promptly. Controls returned under our service policy must be returned by Prepaid transportation. MAGNETROL will repair or replace the control at no cost to the purchaser (or owner) other than transportation if:

1. Returned within the warranty period; and
2. The factory inspection finds the cause of the claim to be covered under the warranty.

If the trouble is the result of conditions beyond our control; or, is NOT covered by the warranty, there will be charges for labor and the parts required to rebuild or replace the equipment.

In some cases it may be expedient to ship replacement parts; or, in extreme cases a complete new control, to replace the original equipment before it is returned. If this is desired, notify the factory of both the model and serial numbers of the control to be replaced. In such cases, credit for the materials returned will be determined on the basis of the applicability of our warranty.

No claims for misapplication, labor, direct or consequential damage will be allowed.

Return Material Procedure

So that we may efficiently process any materials that are returned, it is essential that a "Return Material Authorization" (RMA) number be obtained from the factory, prior to the material's return. This is available through MAGNETROL's local representative or by contacting the factory. Please supply the following information:

1. Company Name
2. Description of Material
3. Serial Number
4. Reason for Return
5. Application

Any unit that was used in a process must be properly cleaned in accordance with OSHA standards, before it is returned to the factory.

A Material Safety Data Sheet (MSDS) must accompany material that was used in any media.

All shipments returned to the factory must be by prepaid transportation.

All replacements will be shipped F.O.B. factory.



705 Enterprise Street • Aurora, Illinois 60504-8149 • 630.969.4000
info@magnetrol.com • magnetrol.com

Copyright © 2019 Magnetrol International, Incorporated